

GT-750ER GT-600ER

75 METRIC TON CAPACITY

60 METRIC TON CAPACITY

GT-300ER

30 METRIC TON CAPACITY

GT-750ER



GT-600ER



GT-300ER



Photo: Optional model



Photo: Optional model

*The GT-750ER/600ER/300ER:
 High Quality We Are Proud Of*

Opening Up New Realms of Cutting-Edge Truck Crane Technology

State-of-the-Art Truck Cranes Crafted in Japan



GT-750ER

Crane capacity: 75,000 kg
 5-section long boom: 47.0 m
 2-staged jib: 9.0 m/14.3 m
 Maximum lifting height: 47.3 m (Boom)
 61.2 m (Jib)
 Maximum load radius: 40.0 m (Boom)
 48.0 m (Jib)

GT-600ER

Crane capacity: 60,000 kg
 5-section long boom: 43.0 m
 2-staged jib: 9.0 m/14.3 m
 Maximum lifting height: 43.4 m (Boom)
 57.3 m (Jib)
 Maximum load radius: 34.0 m (Boom)
 44.0 m (Jib)

GT-300ER

Crane capacity: 30,000 kg
 4-section long boom: 34.0 m
 2-staged jib: 8.5 m/14.0 m
 Maximum lifting height: 34.0 m (Boom)
 48.0 m (Jib)
 Maximum load radius: 32.0 m (Boom)
 40.0 m (Jib)

The GT-750ER/600ER/300ER redefines what truck cranes should be by offering enhanced safety and performance in all crane operations. The newly designed carrier also boasts refined performance, enabling it to withstand even the harshest running test conditions. Tadano has utilized years of development experience to craft this cutting-edge, Japanese-manufactured truck crane.



CONTENTS

Carrier

Two-person, full-width cabin 03
 High performance engine
 Automatic mechanical transmission
 Cruise control
 New suspensions for the carrier
 Test drive for new truck crane

Crane

Rounded construction boom 05
 Two telescoping modes [I] & [II]
 Two winches with cable follower
 Operator Comfort
 Under slung jib
 Automatic moment limiter [AML-C] 07
 Control of asymmetric extension width of outriggers
 Smart Chart system
 HELLO-NET
 Reduce fuel consumption

WORKING RANGE & DIMENSIONS 09
 COUNTERWEIGHT (GT-750EL)
 OPTIONAL ITEMS

Carrier



GT-750ER

Overall length: approx. 14,180 mm
 Overall width: approx. 2,800 mm
 Overall height: approx. 3,740 mm
 Max. traveling speed: 85 km/h



GT-600ER

Overall length: approx. 13,140 mm
 Overall width: approx. 2,800 mm
 Overall height: approx. 3,780 mm
 Max. traveling speed: 85 km/h



GT-300ER

Overall length: approx. 12,620 mm
 Overall width: approx. 2,550 mm
 Overall height: approx. 3,800 mm
 Max. traveling speed: 85 km/h

Photo: Optional model

The carrier has been newly designed, right down to the suspension, to pass long and rigorous road tests in a variety of environments and substantially improve crane mobility. The cabin has also been remodeled with features that contribute to comfortable and safe driving, such as automatic mechanical transmission.



Two-person, full-width cabin

The full-sized cabin accommodates two passengers, allows comfortable traveling for the operator.

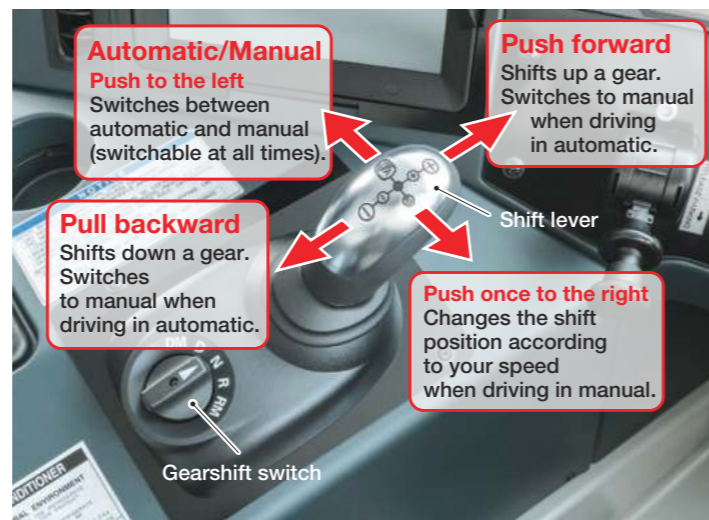

Automatic mechanical transmission

Front: Reyco leaf-type suspensions *GT-750ER, GT-600ER

Sachs shock absorbers
 Improved ride comfort and operability.



New suspensions for the carrier

The ride quality has been optimized to ensure the driver's comfort and protect the carrier.



HENDRICKSON
 The World Rides On Us®

Rear: Rubber suspension mounts

Featuring rubber suspension co-developed with Hendrickson
 Extreme durability proven in the harshest environments.
 Improved ride comfort and maintainability.

Cruise control

A system that automatically controls the speed of the carrier



High-speed driving and durability performance tests for the new truck crane

- Maximum speed test
- Road-holding ability test
- ABS test
- Brake performance test
- Road driving durability test: 15,000km



High performance engine [EURO III]

Daimler OM457LA *GT-750ER, GT-600ER
 4-cycle, turbo charged and after cooled
 Max. output: 260 kW {353 PS}
 Max. torque: 1,850 Nm {188 kgf-m}



Daimler OM926LA *GT-300ER
 4-cycle, turbo charged and after cooled
 Max. output: 240 kW {326 PS}
 Max. torque: 1,300 Nm {132 kgf-m}

Crane

The rounded boom is made of high tensile steel which decreases its weight while increasing its strength to realize smooth and powerful crane operation, while the high-performance AML-C assists with safe and comfortable operation. In addition, the newly developed Smart Chart expands workability into whole new areas to improve operation efficiency.



GT-750ER
 Crane capacity: 75,000 kg
 5-section long boom: 47.0 m
 2-staged jib: 9.0 m/ 14.3 m
 Maximum lifting height: 47.3 m (Boom)
 61.2 m (Jib)
 Maximum load radius: 40.0 m (Boom)
 48.0 m (Jib)

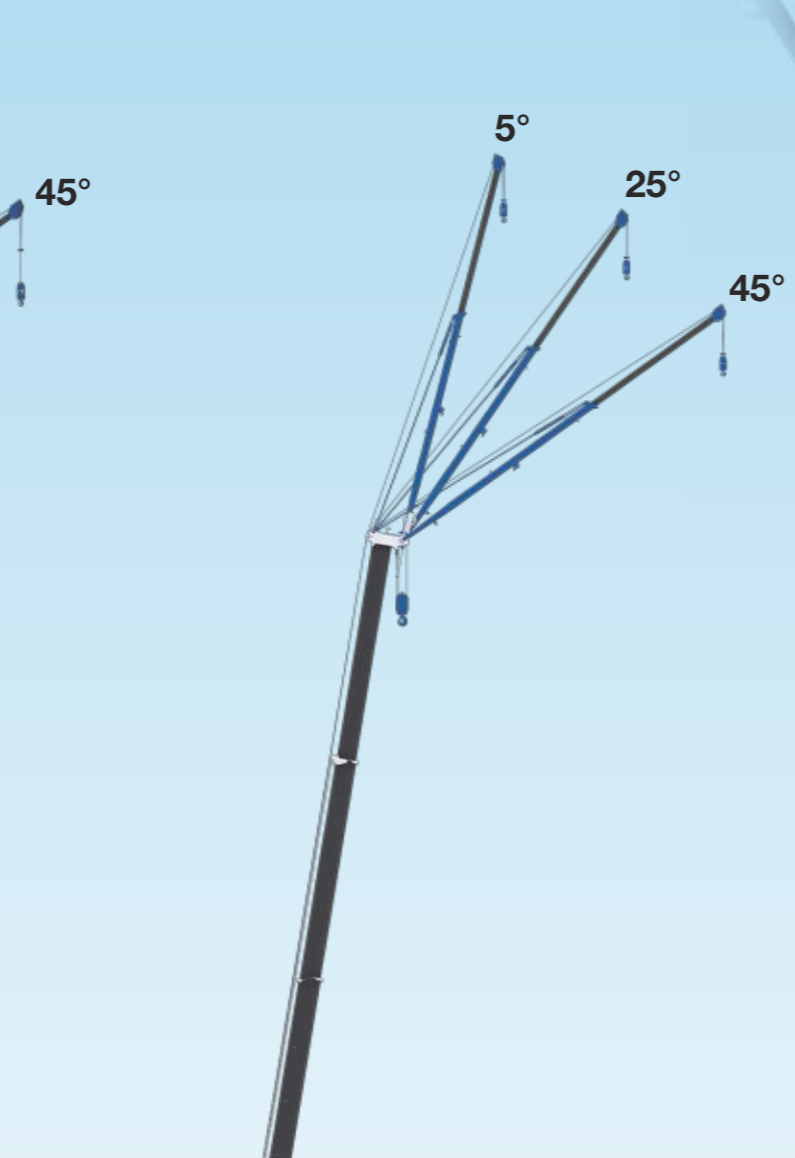
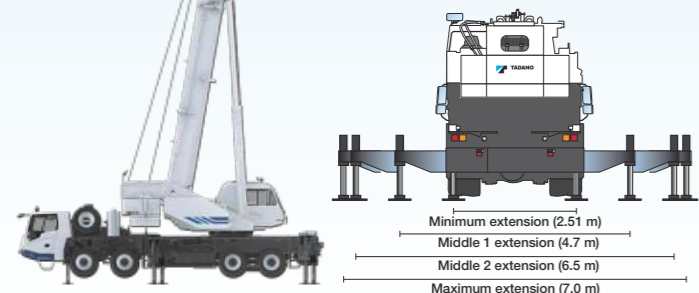

GT-600ER
 Crane capacity: 60,000 kg
 5-section long boom: 43.0 m
 2-staged jib: 9.0 m/ 14.3 m
 Maximum lifting height: 43.4 m (Boom)
 57.3 m (Jib)
 Maximum load radius: 34.0 m (Boom)
 44.0 m (Jib)

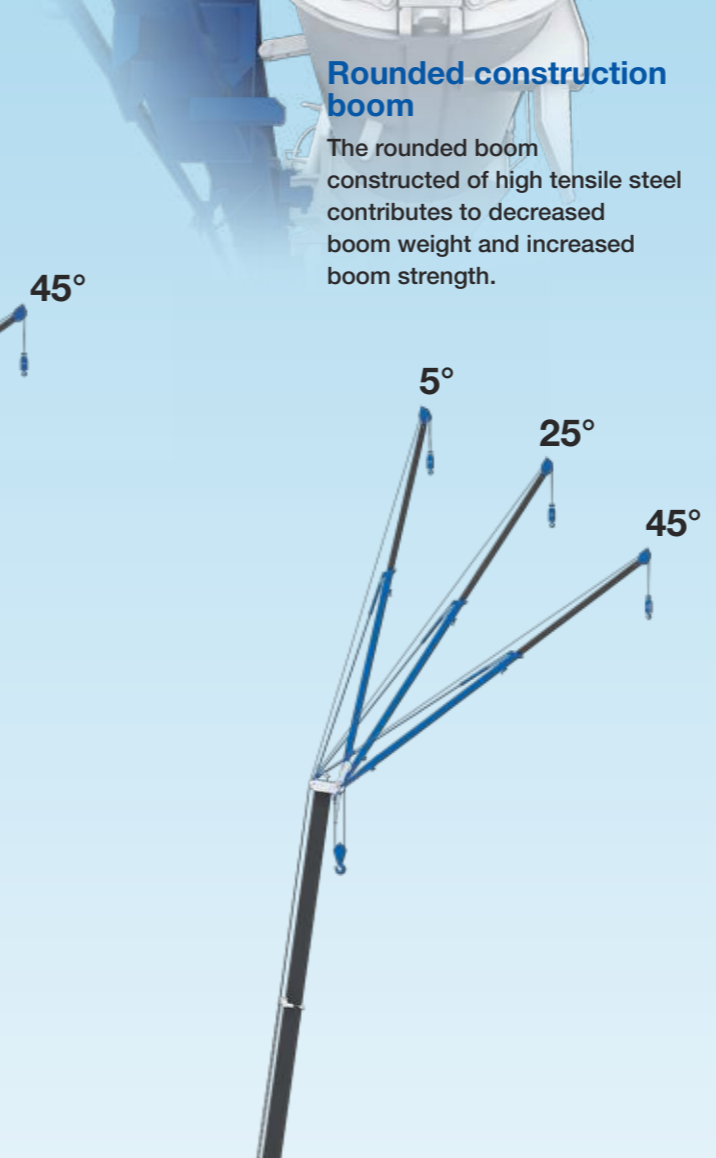
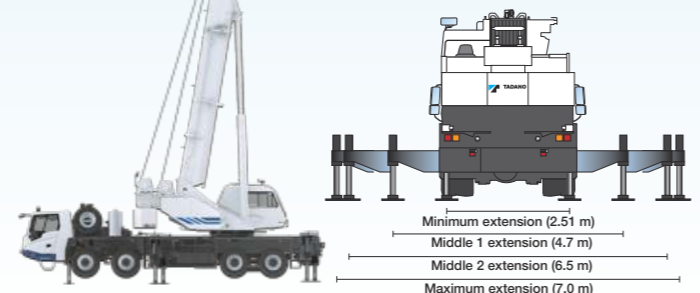

GT-300ER
 Crane capacity: 30,000 kg
 4-section long boom: 34.0 m
 2-staged jib: 8.5 m/ 14.0 m
 Maximum lifting height: 34.0 m (Boom)
 48.0 m (Jib)
 Maximum load radius: 32.0 m (Boom)
 40.0 m (Jib)

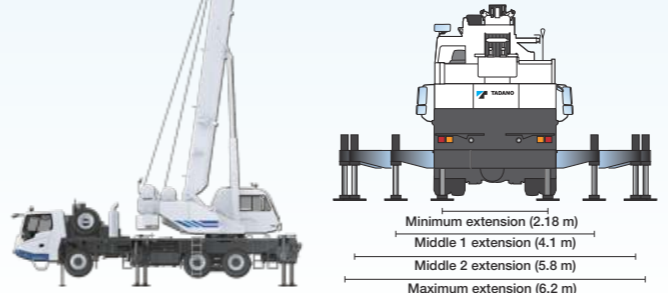

Photo: Optional model

Rounded construction boom

The rounded boom constructed of high tensile steel contributes to decreased boom weight and increased boom strength.

Two telescoping modes [I] & [II] *GT-750ER, GT-600ER

The operator can select either of the two boom telescoping modes based on the designated job plan. This provides enhanced crane capabilities in accordance with work needs.

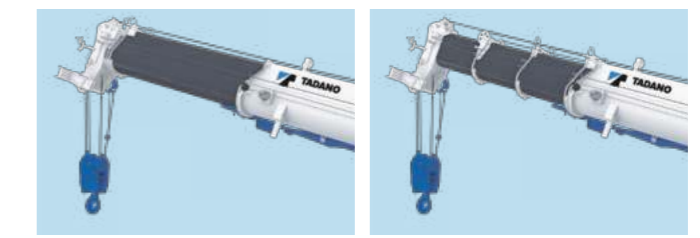

Mode [I]

Mode [I] is extension of 2nd section only. Then synchronized extension of 3rd, 4th and 5th sections.

Mode [II]

Mode [II] is synchronized extension of 3rd, 4th and 5th sections. Then 2nd section independently.

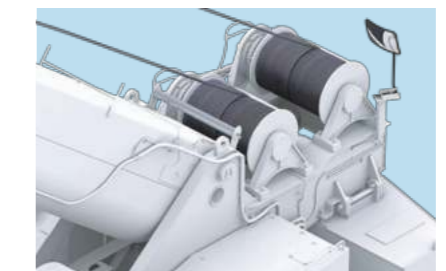

Two winches with cable follower

Both the main winch and the auxiliary winch have powerful line pull (GT-750ER: 5.6-ton, GT-600ER/300ER: 4.5-ton) and operate at high speeds for increased work efficiency.



Operator Comfort

The crane cabin provides improved livability and offers the operator a comfortable working environment.

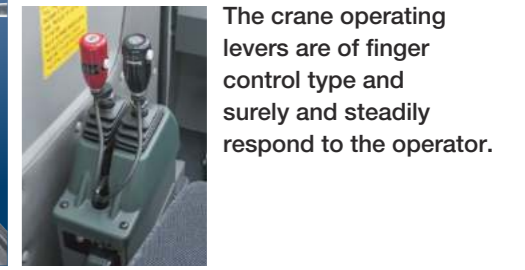

The crane operating levers are of finger control type and surely and steadily respond to the operator.

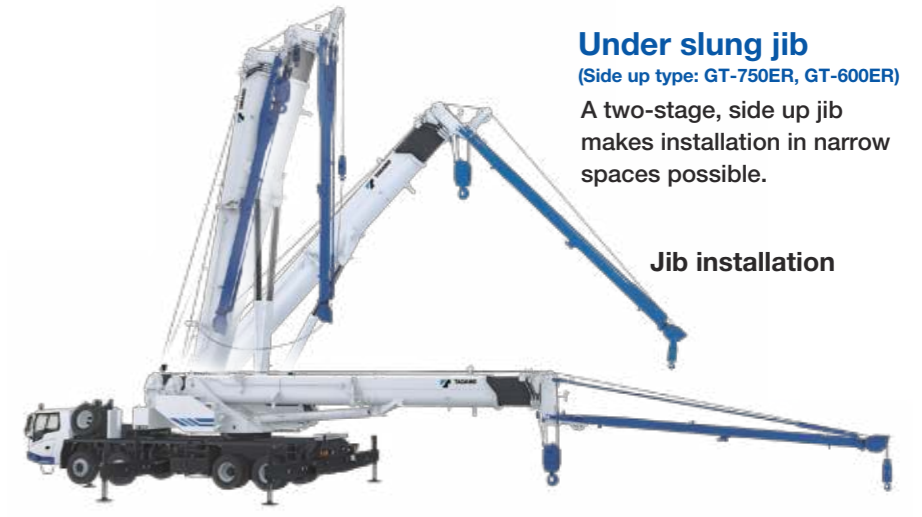

Under slung jib

(Side up type: GT-750ER, GT-600ER)
 A two-stage, side up jib makes installation in narrow spaces possible.

Jib installation

Automatic moment limiter [AML-C]



Tadano's new AML-C is easy to use. It allows the operator to simultaneously monitor: boom angle, boom length, operating pressure of the elevating cylinder, the extension width of outriggers, slewing position, rated lifting capacity and present hook load. All of this enables the AML-C to move easily through lifting capacity changes without changing configurations and codes to make a lift. The AML-C provides both audio and visual warnings when a condition exists that will overload the crane and automatically employs our slow stop function to avoid shock loads. The AML-C with "OPERATOR" pre-set working range limits and automatic slow stop functions will assist the operator to deliver safe smooth operations.



AML lamp

Control of asymmetric extension width of outriggers

When operating the crane with the asymmetric outriggers extended, the AML-C detects the extension width of all of the crane's outriggers (front, rear, left and right) to measure maximum work capacity in each area.

When slewing the boom from the longer outrigger area to the shorter outrigger area, the AML-C detects the motion and displays the maximum capacity according to the extension width of each of the outriggers, and brings the motion to a slow stop before it reaches the maximum capacity.

Regardless of operator awareness, the AML-C's slow stop function will help to minimize any safety risk.

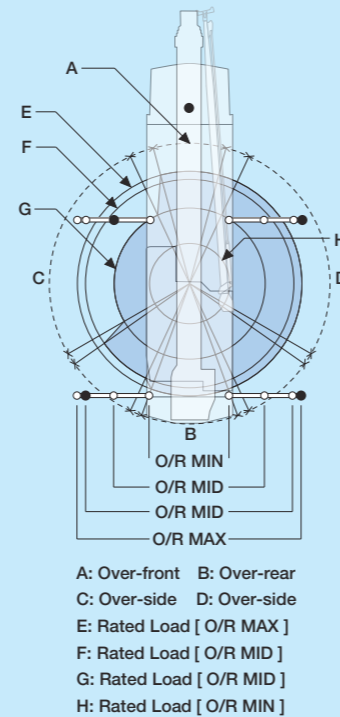
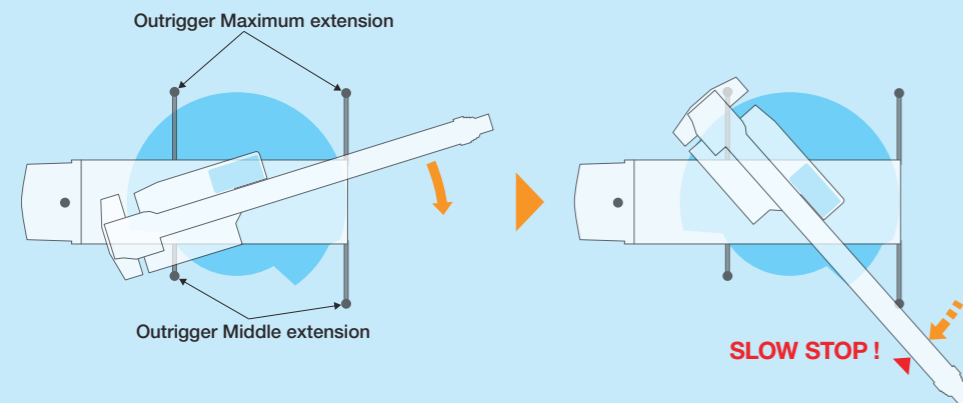

Smart Chart system

*GT-750ER, GT-600ER

The newly developed Smart Chart expands the working area, allowing you to get the best crane performance in any outrigger extension setup.

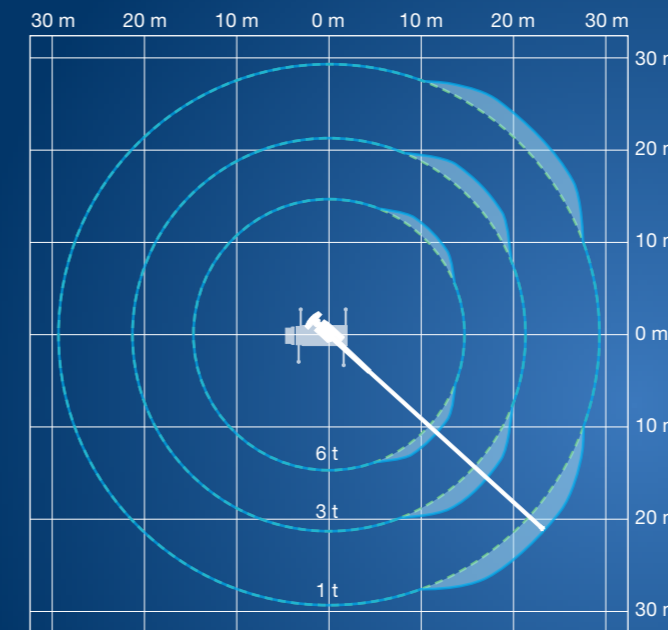

Performance comparison graph (GT-600ER)
[Slewing range: 125 to 145 degrees]

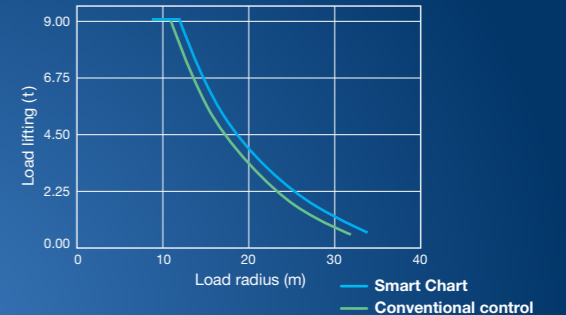

An example of effects with the Smart Chart
(Comparison with conventional control)

Load radius 31.4 m → 34 m

Approx. 8.3% expansion

Load lifting capacity 0.7 t → 1.01 t

Approx. 44.3% expansion

Smart Chart creates a new working area for you

Tadano's new Smart Chart taps into a crane's full potential by expanding the rear part of the conventional circular work area into a square for increased load radius when the outriggers are extended to improve safety and efficiency.

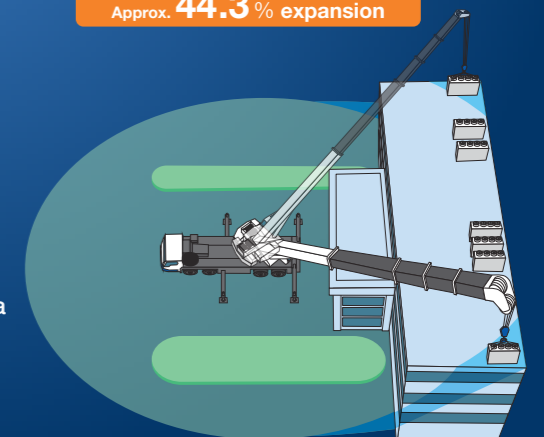

HELLO-NET

The HELLO-NET System is used to monitor crane activity straight from your computer or mobile device.

You have the ability to view work history, machine position data and maintenance information.

HELLO-NET provides advanced customer support between the owners' site and TADANO Group.

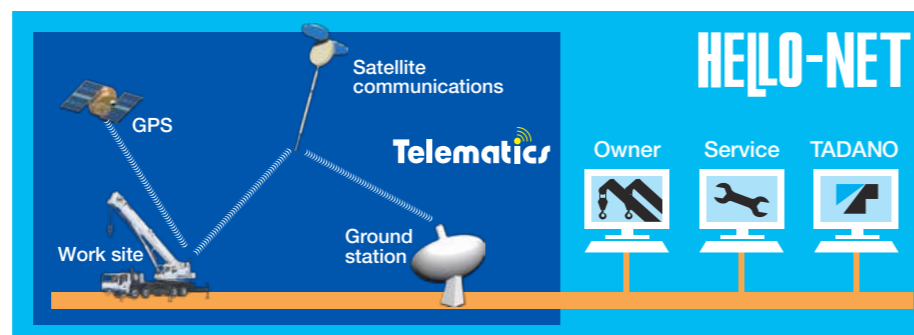

Note: HELLO-NET availability varies by situation. For detail, please contact your distributor or our sales staff in charge.

Reduce fuel consumption



Positive Control System

The system effectively controls the quantity of hydraulic pump discharge at the time of crane operation in response to the amount of movement applied by the operating lever.



Eco Mode System

The system controls the maximum engine speed during crane operation.



Eco mode switch

Fuel consumption
CO₂ emissions
[Compared with GT-600EX]

Down
max.
15%

GT-750ER

Down
max.
35%

GT-600ER

* The above figures differ according to the type of a crane used and its operating conditions.

GT-750ER

WORKING RANGE

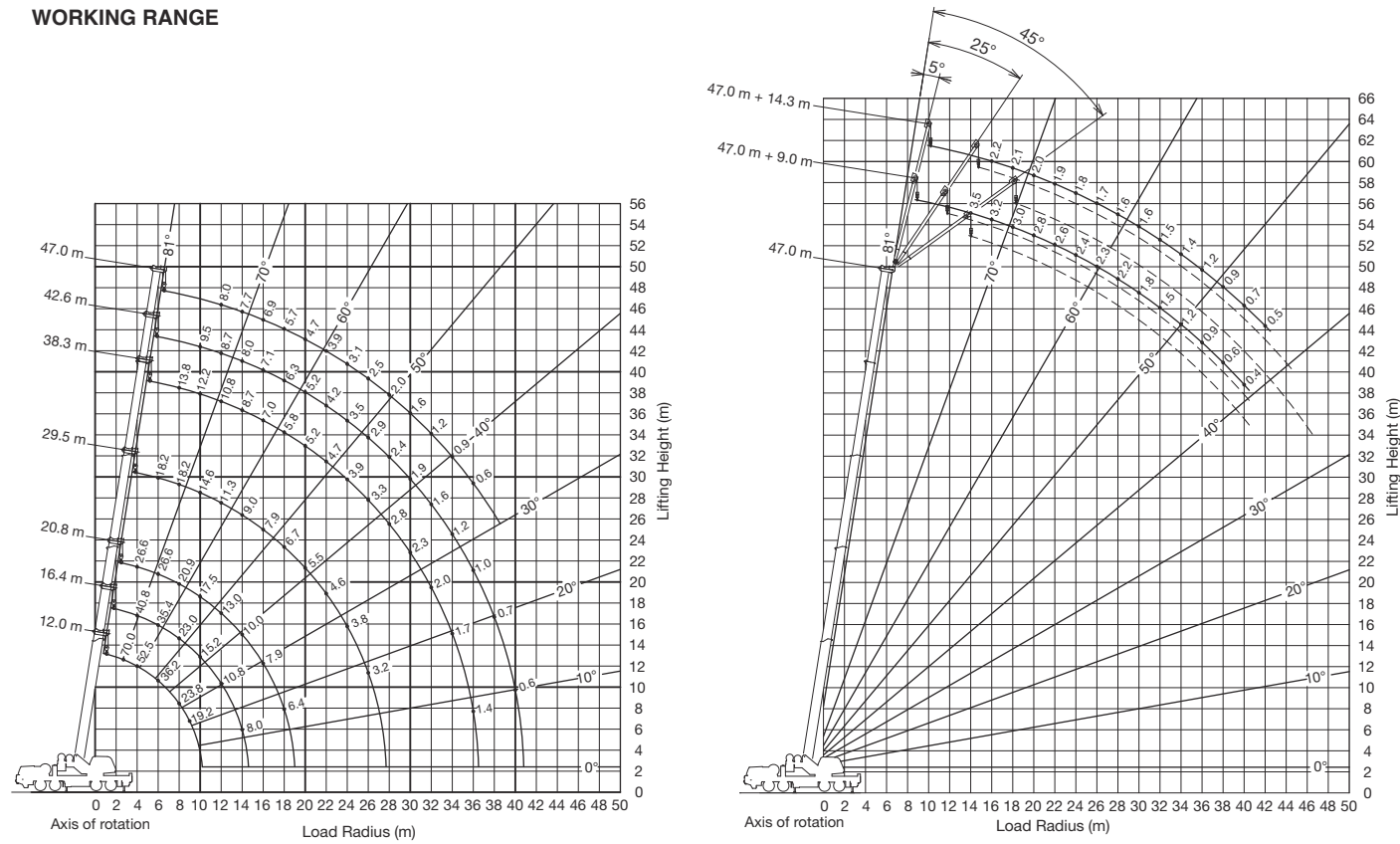

Continuing technical development requires Tadano to retain the right to make specifications, equipment and price changes without notice.

DIMENSIONS

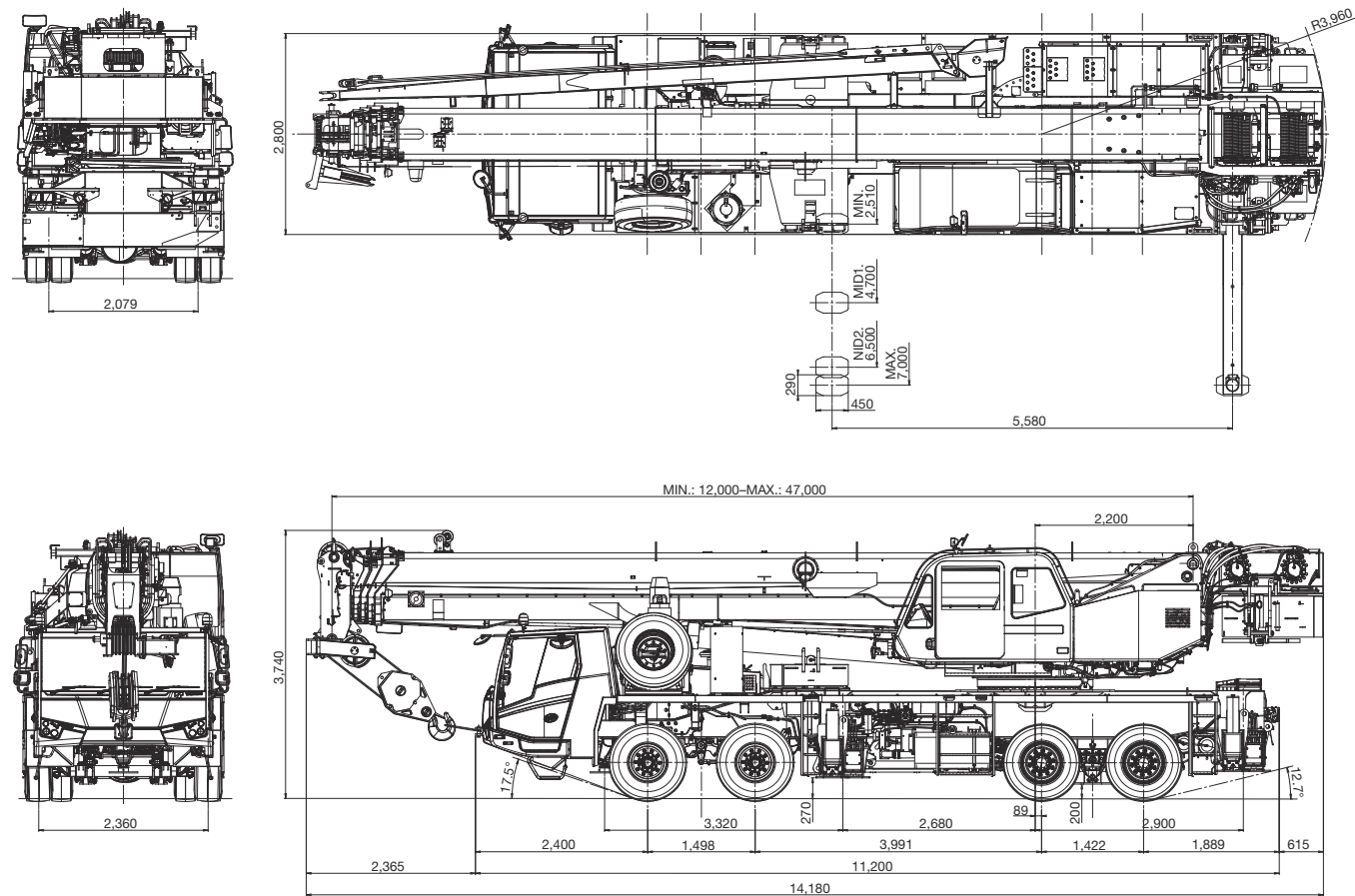

*Some specifications are subject to change

COUNTERWEIGHT GT-750ER: Mass... 7.7 t

Fixed counterweight: Mass... 4.0 t

Self-Removable counterweight: Mass... 1.0 t

Self-Removable counterweight: Mass... 2.7 t

Self-Removable counterweight

Counterweight is hydraulically mounting/dismounting; in addition, dismantled counterweights can be lifted and moved for transport without a helper crane, as well as being re-mounted at a work site for operation.



Counterweight mounting/dismounting switch



OPTIONAL ITEMS



Search light *GT-600ER, GT-750ER

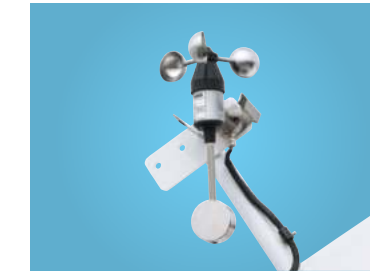

Wind speed indicator



Beacon lamp



Winch drum camera and monitor



External lamp (AML) LED



Rear view camera (monitor: standard)



Side marker lamp

- ABS
- Spark arrester(Euro3)
- 400 L fuel tank
- Rear fog lamp
- Spare tire and bracket
- Stepladder(capacity 100 kg)

GT-600ER

WORKING RANGE

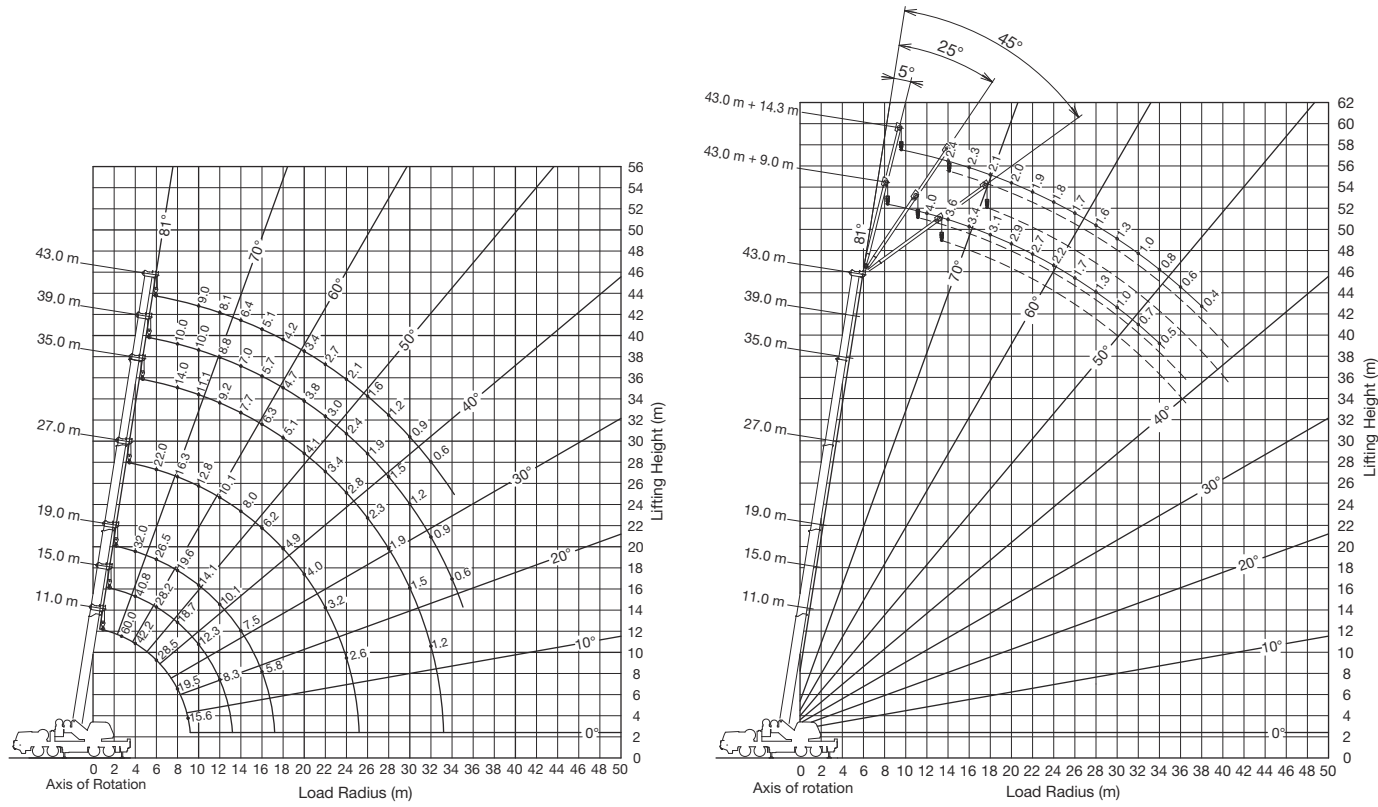

Continuing technical development requires Tadano to retain the right to make specifications, equipment and price changes without notice.

DIMENSIONS

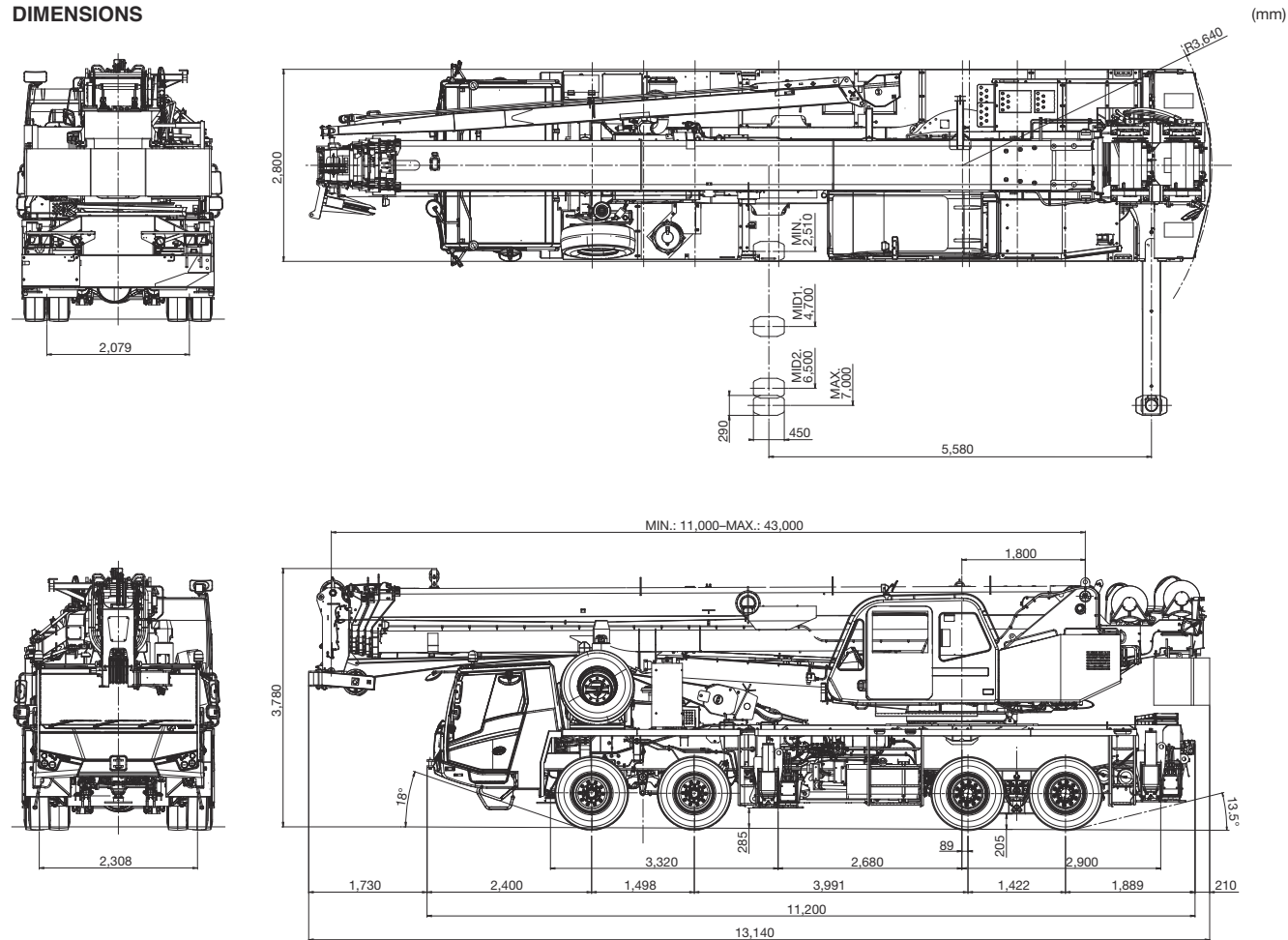

*Some specifications are subject to change

GT-300ER

WORKING RANGE

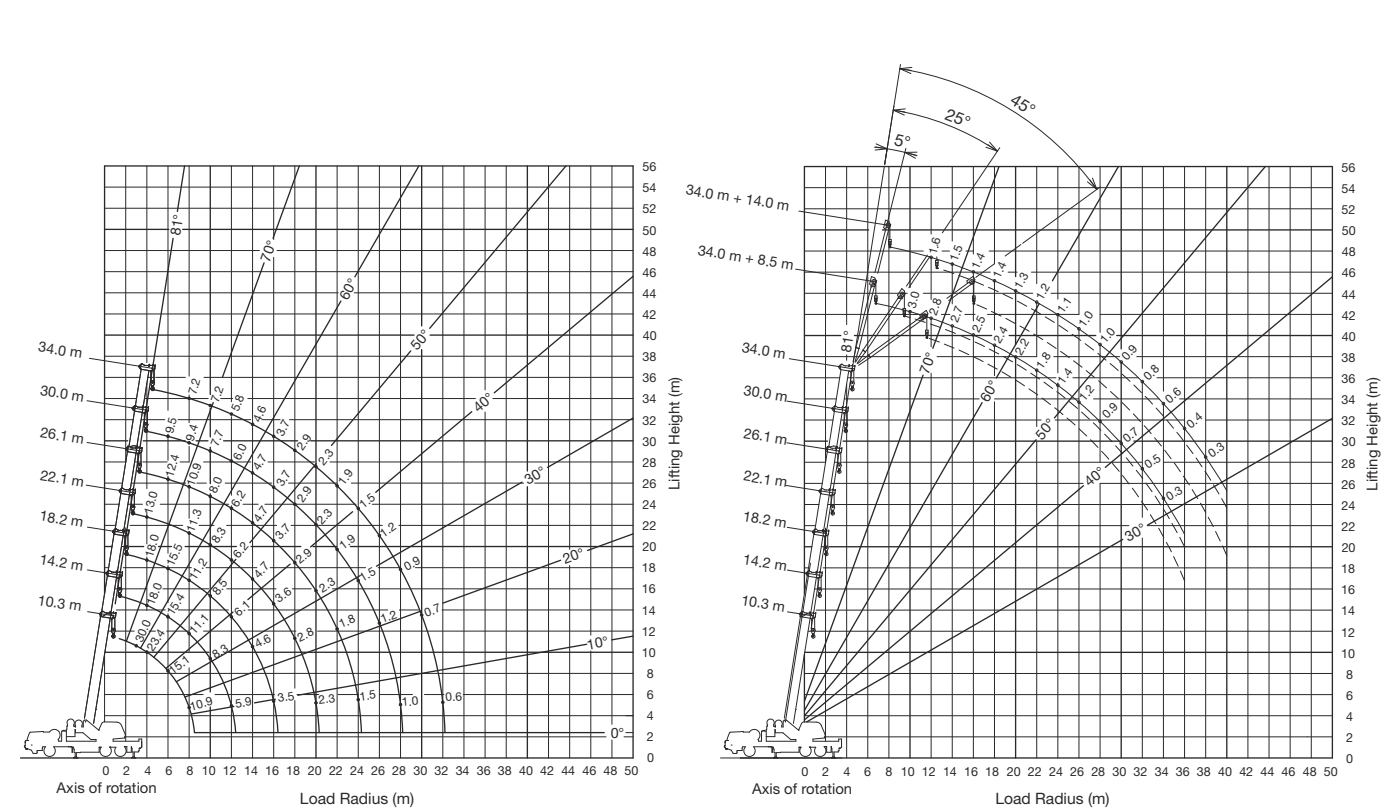

Continuing technical development requires Tadano to retain the right to make specifications, equipment and price changes without notice.

DIMENSIONS

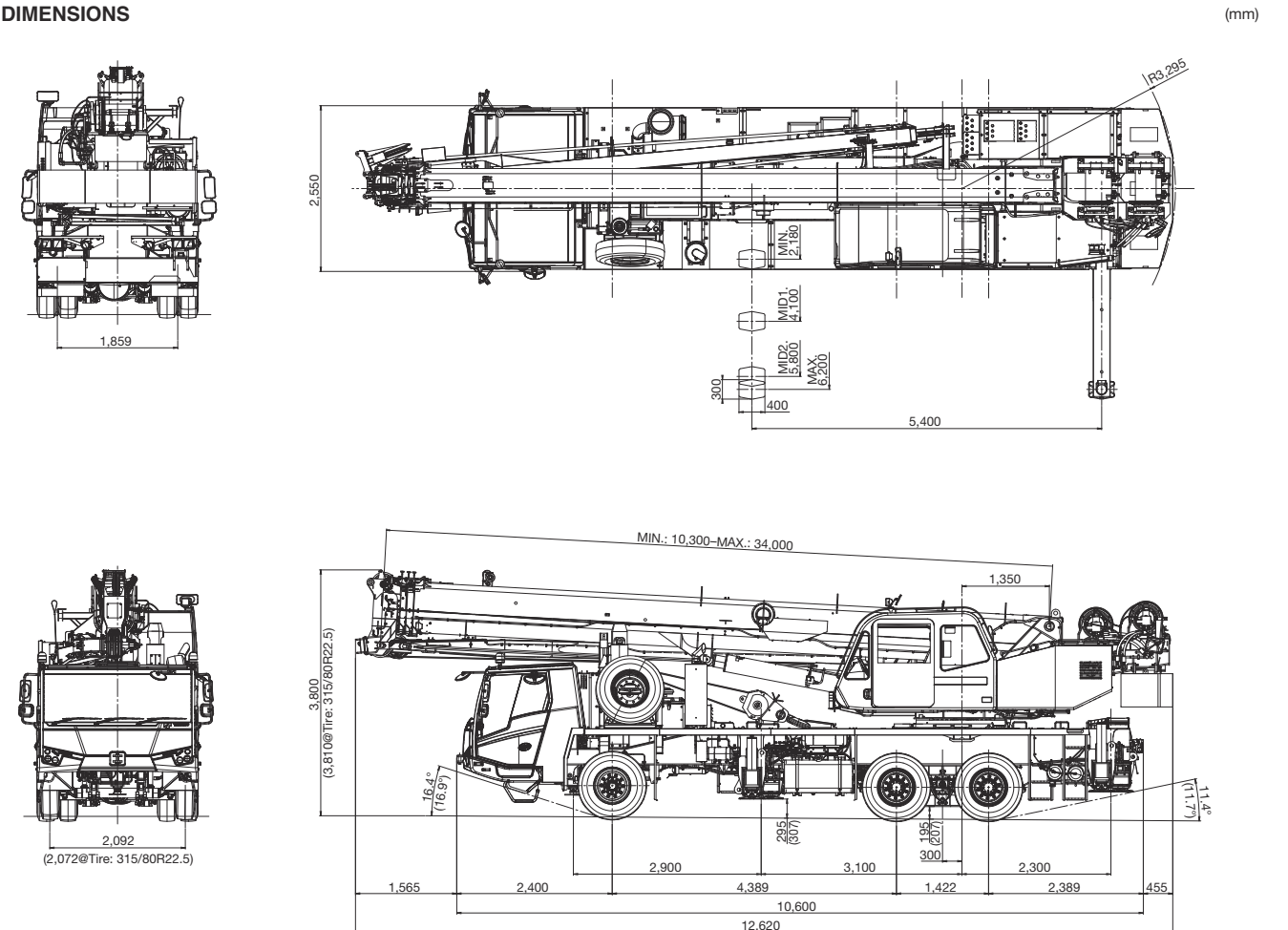

*Some specifications are subject to change