

# Hiab Multilift XP Classic range hooklifts



Basic Data

# XP18T

## Technical data

### Type

### XP18T

|                                   |        |      |
|-----------------------------------|--------|------|
| Vehicle type                      | 3 axle |      |
| GVW of the vehicle (t)            | 26     |      |
| Capacity (t)                      | 18     |      |
| G-length                          | 46     | 51   |
| System weight (kg) *              | 1780   | 1880 |
| Tipping angle (°)                 | 50     | 49   |
| Max. operating pressure (MPa)     | 30     |      |
| Recommended max. oil flow (l/min) | 80     |      |

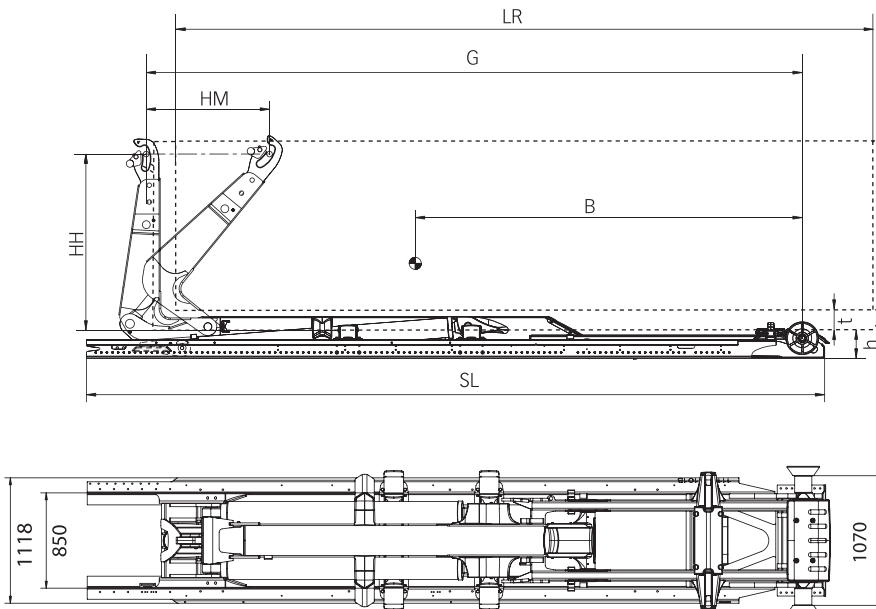

\* Weight includes hydraulic body locking and excludes oil tank and oil.

\*\* The subframe length (SL) can be reduced to achieve a final installation length. The minimum installation length depends upon country and control valve position. For an exact installation length dimension please contact your local Hiab Multilift dealer.

\*\*\* Other hook heights for different body standards available.

Hiab Multilift equipments meet the demands set forth in the EU Machine Directive and they can be CE marked. We reserve the rights for modifications. Illustrations do not always show an equipment in standard version.

## Primary dimensions

### Model

### XP18T.46

### XP18T.51

|  |           |           |
|--|-----------|-----------|
| LR = Body length (m) (min – max)       | 3.8 - 5.6 | 4.3 - 6.1 |
| SL = Subframe length (mm) **           | 5308      | 5758      |
| B = Centre of gravity (mm)             | 2550      | 2800      |
| G = Exact G-length (mm)                | 4580      | 5080      |
| HM = Horizontal movement (mm)          | 1100      | 1100      |
| t = Min free tunnel height (body) (mm) | 125       |           |
| h = Installation height (mm)           | 230       |           |
| HH = Hook height (mm) ***              | 1570      |           |

*Cargotec improves the efficiency of cargo flows on land and at sea - wherever cargo is on the move. Cargotec's brands MacGregor, Kalmar and Hiab are recognised leaders in cargo and load handling solutions around the world. Cargotec's global network is positioned close to customers and offers extensive services that ensure the continuous, reliable and sustainable performance of equipment. [www.cargotec.com](http://www.cargotec.com)*



**Cargotec Finland Oy**  
 Nesteentie 36, P.O.Box 39  
 FI-21201 Raisio, Finland  
 tel. +358 204 55 2399  
 fax +358 204 55 2231  
[www.hiab.com](http://www.hiab.com)