

# AT-157CG



**Maximum working height**  
17.7 m

**Maximum basket bottom height**  
15.7 m

**Maximum working radius**  
10.2 m

**Maximum basket loading capacity**  
200 kg or two (2) persons

**MODEL: AT-157CG**  
**SPECIFICATIONS**

MAX. BASKET BOTTOM HEIGHT	15.7 m
BASKET EQUIPMENT	
Basket	Pipe made
Inside dimensions	0.7 m x 1.2 m x 0.95 m (L x W x D)
Capacity	200 kg or two (2) persons
Automatic leveling system	By hydraulic cylinders with link.
Slewing angle	190° (Left 95°, Right 95°)
BOOM	3-section full power synchronized telescoping boom of box construction. The synchronization system consists of a double-acting hydraulic cylinder, an extension cable and a retraction cable. Hydraulic cylinder fitted with a holding valve and a pilot check valve. And articulating boom of box construction. The articulation system consists of a double-acting cylinder with holding valves and links.
Fully retracted length	5.41 m + 3.05 m (Articulating)
Fully extended length	11.93 m + 3.05 m (Articulating)
Extension speed	6.52 m in 30 s
Articulating speed	0° to 170° in 30 s
ELEVATION	By a double-acting hydraulic cylinder, fitted with a holding valve.
Elevation speed	-16° to 80° in 35 s
SLEWING	Hydraulic motor driven through worm reduction gear. 360° continuous in either direction on ball bearing slew ring.
Slewing speed	1.0 min <sup>-1</sup> {rpm}
HYDRAULIC SYSTEM	
Pumps	Gear pump
Control valves	Multiple hydraulic-control valves actuated by switch with integral relief valves, on slewing frame. And electric remote control from basket.
Hydraulic oil tank capacity	Approx. 63 L
Filter	Return line filter

OUTRIGGERS	4 hydraulically operated outriggers. Each outrigger controlled simultaneously or independently from rear side of carrier. Equipped with sight level gauge. Floats mounted integrally with the jacks and retract to within vehicle width. All cylinders fitted with pilot check valves.
Fully extended width	3.3 m
SAFETY DEVICES	<ul style="list-style-type: none"> <li>• Automatic working area limiter (AMC)</li> <li>• Boom profile monitor system (Prevent hitting vehicle by boom and by basket, prevent hitting basket by articulating boom)</li> <li>• Automatic speed control system on boom elevation, slewing and articulating</li> <li>• Automatic speed reduction and slow stop function on boom elevation, slewing, telescoping and articulating</li> <li>• Automatic acceleration</li> <li>• Boom vertical/horizontal movement device</li> <li>• Boom and basket automatic stowing</li> <li>• Emergency pump</li> <li>• Emergency stop system</li> <li>• Parking brake warning</li> <li>• PTO connect warning (when drive)</li> <li>• Jack interlock • Boom interlock • Outrigger indicator • Hydraulic cylinder lock valves</li> <li>• Hydraulic safety valves • Level gauge • Guard for operation levers • Foot switch (on basket)</li> </ul>
ACCESSORIES	<ul style="list-style-type: none"> <li>• Hour meter • Rubber blocks (for outriggers)</li> <li>• Chocks</li> </ul>
OPTIONAL EQUIPMENT	<ul style="list-style-type: none"> <li>• Work light (on basket) • Safety belt</li> <li>• Wood block (for outrigger) • Grease pump</li> <li>• Tools</li> </ul>

**WORKING RANGE**

**DIMENSIONS (Approx.)**

(mm)

Basket loading capacity:  
200 kg or 2 persons

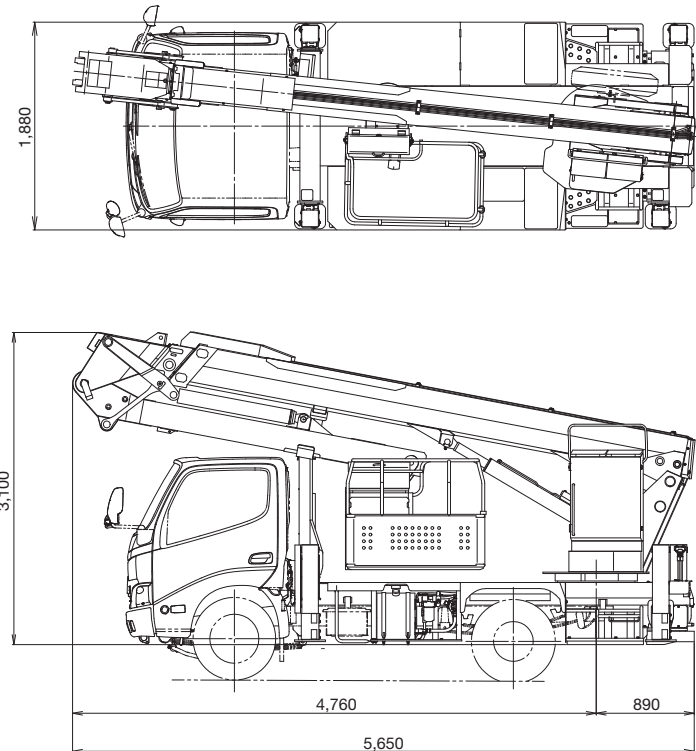
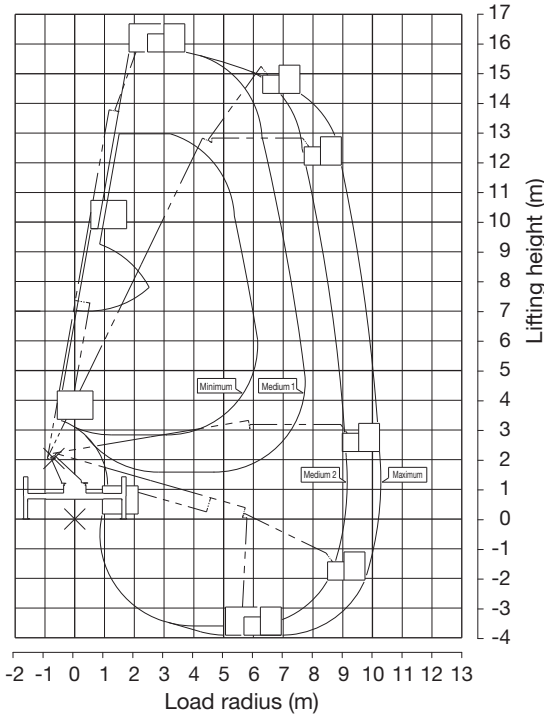

NOTE: Some specifications are subject to change.



**Tadano Ltd.**

KANDA SQUARE 18th Floor, 2-2-1 Kanda-Nishikicho,  
Chiyoda-ku, Tokyo 101-0054, Japan  
Phone: +81-3-6811-7309  
info@tadano.com www.tadano.com

